



Reference Manual

Ver. 1.2

P DX 3010 Audio Monitoring Deembedder with Analog Video Output

Series 3000
MiniModules

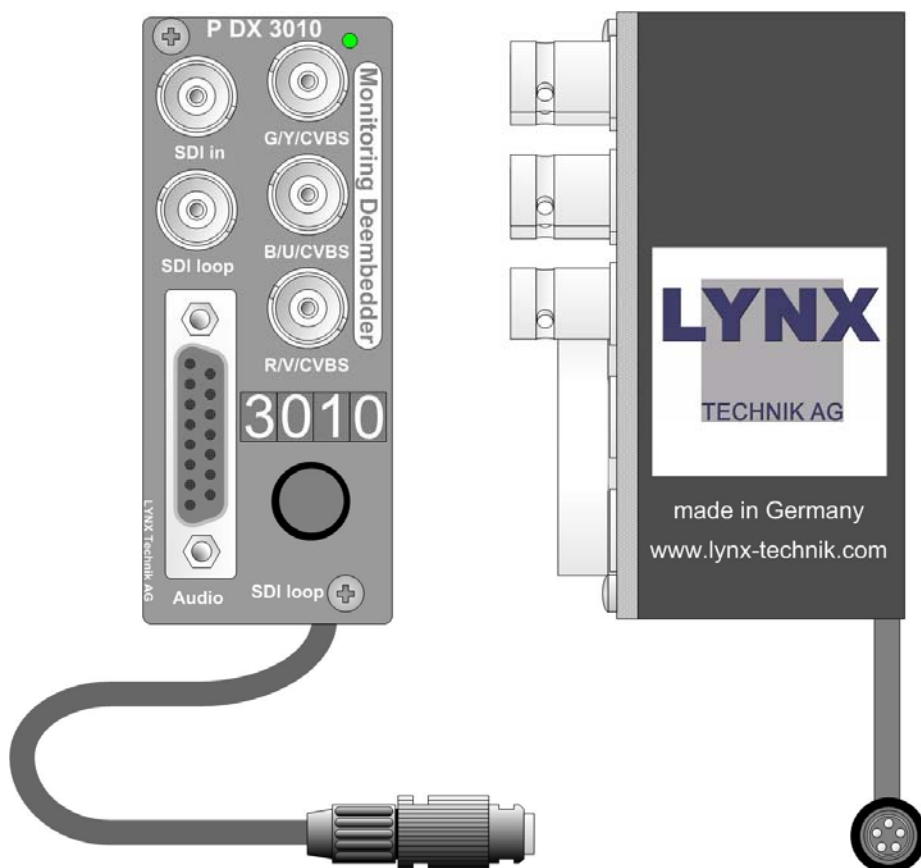

© LYNX Technik AG
Brunnenweg 3
64331 Weiterstadt
Germany
www.lynx-technik.com

Information in this document is subject to change without notice. No part of this document may be reproduced or transmitted in any form or by any means, electronic or mechanical for any purpose, without express written permission of LYNX Technik AG.

LYNX Technik AG may have patents, patent applications, trademarks, copyrights or other intellectual property rights covering the subject matter in this document. Except as expressly written by LYNX Technik AG, the furnishing of this document does not give you any license to patents, trademarks, copyrights or other intellectual property of LYNX Technik AG or any of its affiliates.

© LYNX Technik AG 2004 - 2005 all rights reserved

Warranty

LYNX Technik AG warrants that the product will be free from defects in materials and workmanship for a period of two (2) years from the date of shipment. If this product proves defective during the warranty period, LYNX Technik AG at its option will either repair the defective product without charge for parts and labor, or will provide a replacement in exchange for the defective product.

In order to obtain service under this warranty, customer must notify LYNX Technik of the defect before expiration of the warranty period and make suitable arrangements for the performance of service. Customer shall be responsible for packaging and shipping the defective product to the service center designated by LYNX Technik, with shipping charges prepaid. LYNX Technik shall pay for the return of the product to the customer if the shipment is within the country which the LYNX Technik service center is located. Customer shall be responsible for payment of all shipping charges, duties, taxes and any other charges for products returned to any other locations.

This warranty shall not apply to any defect, failure, or damage caused by improper use or improper or inadequate maintenance and care. LYNX Technik shall not be obligated to furnish service under this warranty a) to repair damage resulting from attempts by personnel other than LYNX Technik representatives to install, repair or service the product; b) to repair damage resulting from improper use or connection to incompatible equipment; c) to repair any damage or malfunction caused by the use of non LYNX Technik supplies; or d) to service a product which has been modified or integrated with other products when the effect of such modification or integration increases the time or difficulty servicing the product.

THIS WARRANTY IS GIVEN BY LYNX TECHNIK WITH RESPECT TO THIS PRODUCT IN LIEU OF ANY OTHER WARRANTIES, EXPRESS OR IMPLIED. LYNX TECHNIK AND ITS VENDORS DISCLAIM ANY IMPLIED WARRANTIES OF MERCHANTABILITY OR FITNESS FOR A PARTICULAR PURPOSE. LYNX TECHNIK`S RESPONSIBILITY TO REPAIR AND REPLACE DEFECTIVE PRODUCTS IS THE SOLE AND EXCLUSIVE REMEDY PROVIDED TO THE CUSTOMER FOR BREACH OF THIS WARRANTY. LYNX TECHNIK AND ITS VENDORS WILL NOT BE LIABLE FOR ANY INDIRECT, SPECIAL, INCIDENTAL, OR CONSEQUENTIAL DAMAGES IRRESPECTIVE OF WHETHER LYNX TECHNIK OR THE VENDOR HAS ADVANCE NOTICE OF THE POSSIBILITY OF SUCH DAMAGES.

Regulatory information

Europe

Declaration of Conformity

We	LYNX Technik AG Brunnenweg 3 D-64331 Weiterstadt Germany
<i>Declare under our sole responsibility that the product</i>	
TYPE: P DX 3010	
<i>To which this declaration relates is in conformity with the following standards (Environments E1-E3):</i>	
EN 55103-1 /1996	
EN 55103-2 /1996	
EN 60950 /2001	
<i>Following the provisions of 89/336/EEC and 73/23/EEC directives.</i>	
	Winfried Deckelmann
Weiterstadt, August 2004	
<i>Place and date of issue</i>	<i>Legal Signature</i>

USA

FCC 47 Part 15

This device complies with part 15 of the FCC Rules. Operation is subject to the following two conditions: (1) This device may not cause harmful interference, and (2) this device must accept any interference received, including interference that may cause undesired operation.

Note: This equipment has been tested and found to comply with the limits for a Class A digital device, pursuant to the part 15 of the FCC Rules. These limits are designed to provide reasonable protection against harmful interference when the equipment is operated in a commercial environment. This equipment generates, uses, and can radiate radio frequency energy and, if not installed and used in accordance with the instruction manual, may cause harmful interference to radio communications. Operation of this equipment in a residential area is likely to cause harmful interference in which case the user will be required to correct the interference at his own expense

Contents

Warranty	3
Regulatory information.....	4
Europe	4
Declaration of Conformity.....	4
USA.....	4
FCC 47 Part 15	4
Contents.....	5
Getting Started	7
Packaging	7
Product Description.....	7
Functional Diagram.....	9
Module Layout.....	9
Connections	11
Audio / Video Connections.....	11
Audio Connector (balanced).....	11
Power Connections	12
DC Power Connector.....	12
Installation	13
Mechanical.....	13
Stand Alone Operation	13
Multiple Units.....	14
Electrical Installation.....	15
Stand Alone Operation	15
Settings and Control	16
Multi Function Switch	16
Using the Local Display Menus.....	16
Navigation	16
Menu Structure.....	16
Factory Preset Condition	17
Front Panel Alarm Indicator	22
Available Options	24
Parts List.....	25
Service	25
Contact Information	26

This Page is intentionally left blank

Getting Started

Packaging

The shipping carton and packaging materials provide protection for the module during transit. Please retain the shipping cartons in case subsequent shipping of the product becomes necessary.

Product Description

The P DX 3010 is a high quality monitoring de-multiplexer (Audio de-embedder), with analog Video and Audio outputs, designed primarily for broadcast and professional applications.

The Module accepts 1 SDI input signal with up to four audio groups embedded. One audio group can be selected and de-multiplexed and output as analog Audio signals on a 110 Ohm SubD15 connection. One reclocked output of the input signal is also provided. The SDI signal can be output as analog video (YUV, RGB or CVBS)

The P DX 3010 has a variety of features, which include:

- User selectable audio groups. (1 through 4)
- Supports 525 / 625 line standards
- Supports 20 and 24 bit audio
- Supports 8 and 10 bit video
- Local matrix display and multifunction switch for control and status monitoring
- All settings stored in non-volatile flash ram
- One reclocked output of input video
- Analog video outputs

The module has a built in micro-controller with local controls, status and alarm indicators and well as internal flash ram for storing setups. Any operational parameters configured and stored into the module are recalled when powered up.

The P DX 3010 is part of the 3000 series of MiniModules, which offer high quality, modularity and flexibility in a very small form factor ideal for applications where space is at a premium.

The modules can be used either stand alone using the optional power supply brick, or as part of a tightly integrated space saving system where up to 10 MiniModules can be mounted utilizing the optional LYNX R FR 3005 / 3010 rack housing. This includes integrated power supply and optional redundant power supply.

Functional Diagram

Figure 1 below is the basic functional diagram for the P DX 3010 MiniModule.

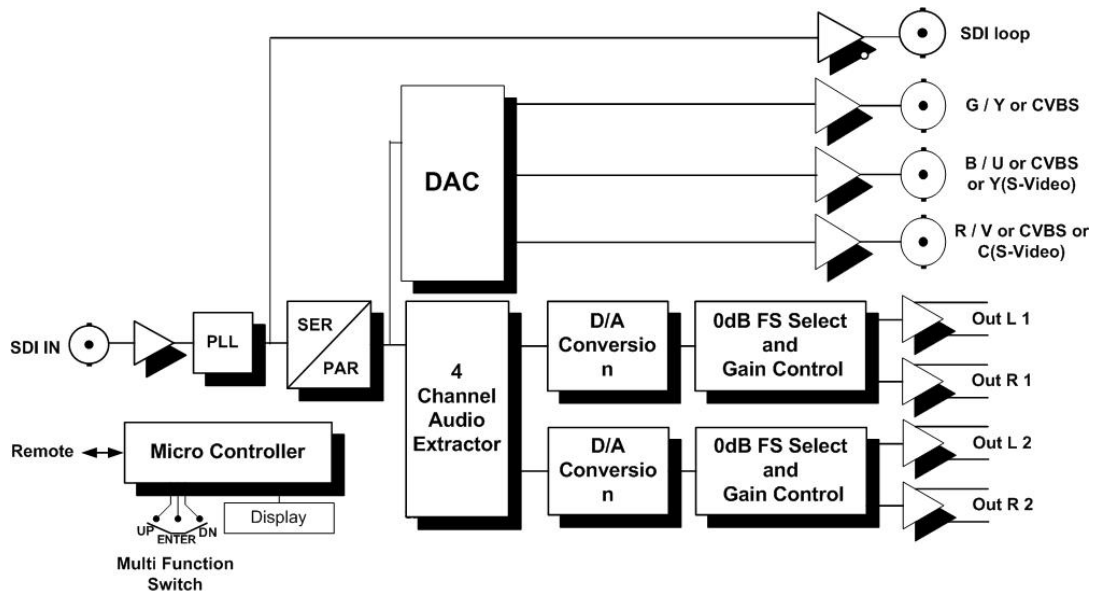

Figure 1- P DX 3010 Functional Diagram

Module Layout

Figure 2 shows the physical layout of the P DX 3010 MiniModule. Video I/O is made through standard 75 Ohm BNC video connections and Audio output through a SubD15 connector. Module configuration is set via multi function switch and a matrix display located on the connector side of the module.

If the module is being used in a stand alone application then the optional power supply (R PS 3001 E, R PS 3001 U or R PS 3001-3) is required to power the module (not shown)

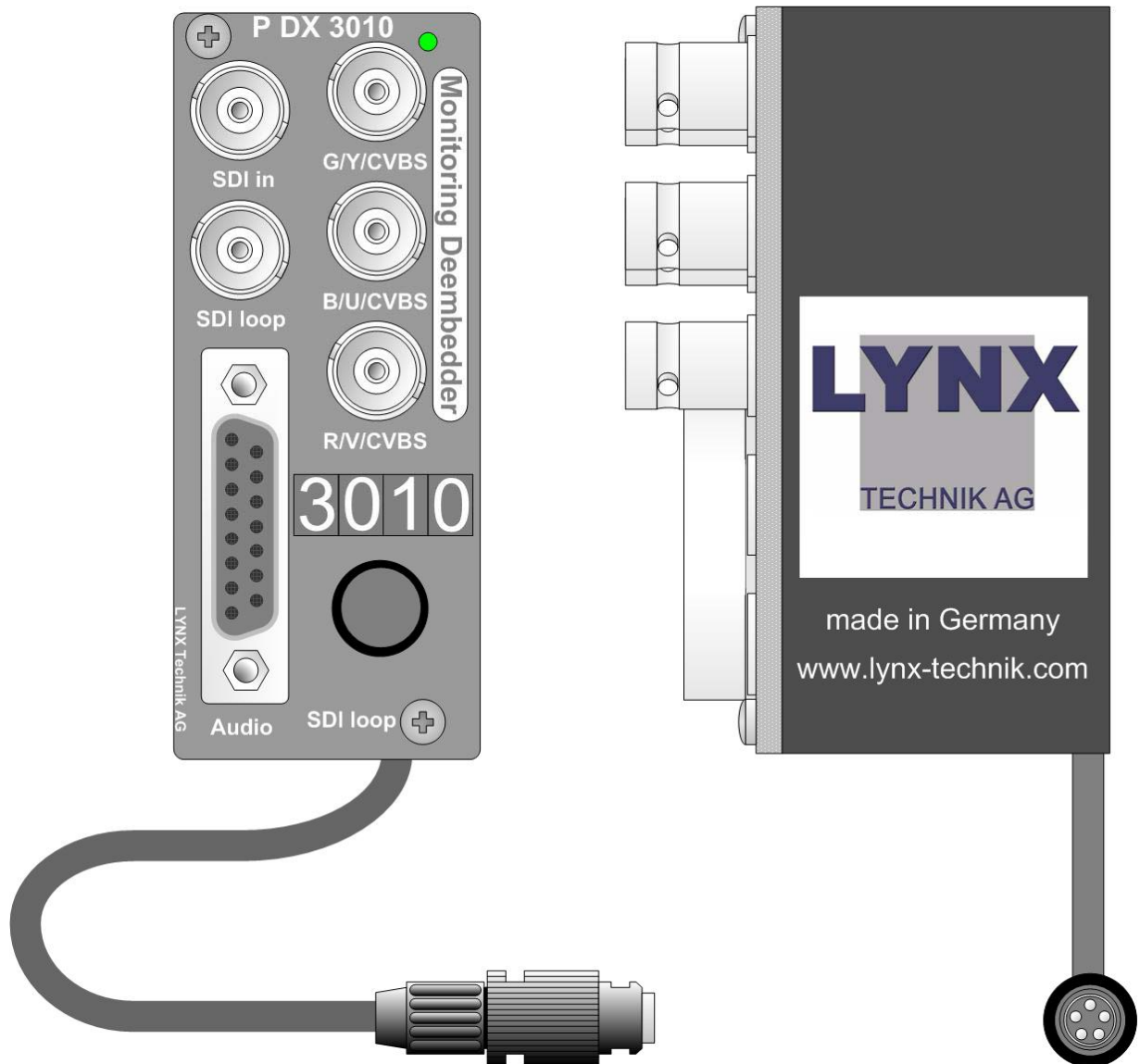

Figure 2 – Module Layout

Connections

Audio / Video Connections

The P DX 3010 MiniModule is configured with standard 75 Ohm BNC connectors for Video I/O. The Audio outputs are provided on a SubD15 connector. Connection is self-explanatory for Video. Audio see below. We recommend the use of high quality video cable suitable for digital video connections to reduce the risk of interference or errors due to excessive cable attenuation.

Note. Due to the compact design of the module it will be necessary to use a connection tool to secure the BNC video connectors to the module.

Audio Connector (balanced)

SubD 15-pin female connector

Pin Number	Connection	Pin Number	Connection
1	+ Audio 1	9	- Audio 1
2	GND Audio 1/2	10	+ Audio 2
3	- Audio 2	11	GND Audio 1/2
4	+ Audio 3	12	- Audio 3
5	GND Audio 3/4	13	+ Audio 4
6	- Audio 4	14	GND Audio 3/4
7		15	
8			

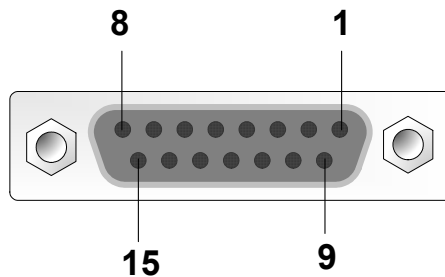

Power Connections

If using the module in a stand-alone application use the separate R PS 3001 E (for Europe), R PS 3001 U (USA) power brick option or the R PS 3001- desk power supply.

DC Power Connector

The MiniModule has a captive power lead fitted to the module, with a male 5 pin locking bayonet connector. This connection provides DC power and also data connectivity to the module. Connector wiring is shown below.

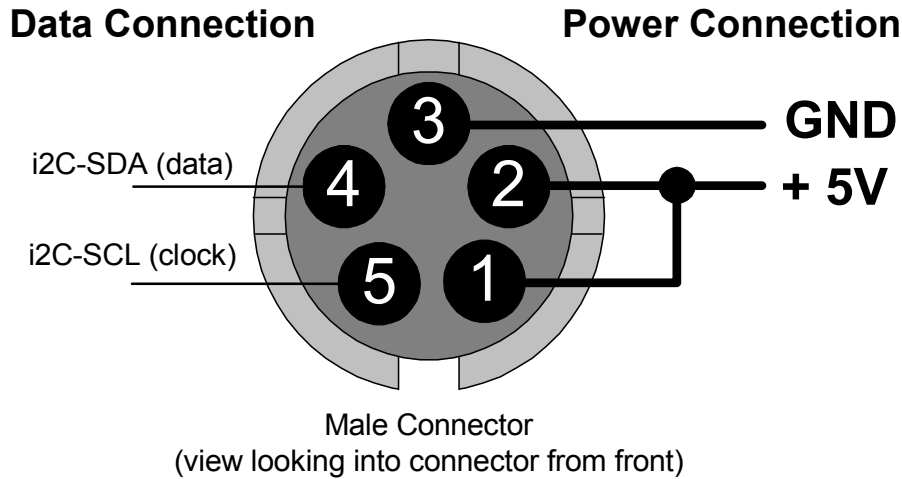

Caution

Only use the optional LYNX R PS power modules. Ensure the 5-pin power connector is locked securely in place.

Installation

Mechanical

Stand Alone Operation

The P DX 3010 MiniModule can be used in a stand alone application. There are two options for the use of the module in this way.

- a) Using the R FR 3005 Rack Frame 1 option. This allows up to any 10 of the MiniModules to be secured onto a rack frame assembly for 19 inch rack mounting. This keeps the modules secured, organized and out of the way. The R PS 3001 power brick option or the R FR 3010 option is required to power each module. Please refer to the R FR 3005 Reference Manual supplied with this option for more details.
- b) Single Use. The MiniModule can be powered independently with the R PS 3001 option and used in any location where this functionality is required.



Caution. Care needs to be taken when using the module in this way, as it is not physically secured. Keep the module away from the floor to avoid the risk of someone stepping or tripping on the unit, and locate the unit away from excessive sources of heat and any sources or moisture.

If using more than one MiniModule in any installation, the R FR 3005/3010 Rack frame combination is highly recommended.

Multiple Units

Most applications will require more than one MiniModule, which can include any of the available Series 3000 MiniModule product range. There are two options for mounting multiple units.

- a) Using the R FR 3005 Rack Frame option. This allows up to any 10 of the MiniModules to be secured onto a rack frame assembly for 19 inch rack mounting. The R PS 3001 power brick option or the R FR 3010 option is required to power each module. Please refer to the R FR 3005 Reference Manual for more details.
- b) Using the R FR 3010 Rack frame extension option. Can be combined with the R FR 3005 Rack frame option. Each module plugs into a connection bus, which provides common power for all modules. (no R PS external power supplies are needed). Please refer to the respective reference manuals for these options for details of mechanical installation.

The very small size and density of the MiniModules combined with the available rack frame options allows the addition of a complex and custom signal distribution system without taking any additional front rack space. The rack frames are designed for installation in the back of 19-inch racks where there is normally plenty of available space. Ideal for mobile truck installations and facility expansions where space is at a premium.

Electrical Installation.

Stand Alone Operation

The MiniModule requires the R PS 3001 power brick option for stand-alone operation. Three versions are available R PS 3001 E for European markets, R PS 3001 U for the US markets and the R PS 3001-3 desk power supply. Please ensure you have the correct power option for your region. The connection to the module is made with a small 5-pin connector, which has a twist bayonet securing system. Please make sure the connection is solid and locked in place. A strain relief is included within the module to prevent excessive strain on the connection.

Signal connections should be made with care, please ensure connections are correct and compatible equipment is feeding / receiving the signals from the module or damage can result.



Caution. Only use the optional LYNX R PS 3001 power modules. Ensure the 5-pin power connector is locked securely in place.



Caution. Care needs to be taken when using the module in this way, if it is not physically secured. Keep the module away from the floor to avoid the risk of someone stepping or tripping on the unit, and locate the unit away from excessive sources of heat and any sources or moisture.

Settings and Control

Multi Function Switch

The MiniModule is equipped with a multi-function switch located on the connector side of the module (refer to figure 2)

The switch can be turned left and right and can be pressed down for ENTER. Turning left and right guides you through the menu.

Using the Local Display Menus

Making local adjustments to the module is done using the multifunction switch and the integrated 4-character dot matrix display (figure 2). The menu system is layered, and navigation through the system is done using the **LEFT** and **RIGHT** functions of the switch. **ENTER** is used to move between menu levels and also enter a selection.

Navigation

Switch Function	Operation
RIGHT	Move UP within a level
LEFT	Move down within a level
ENTER	Change levels / Make selection

Menu Structure

The Menu structure is defined in the next table, and should be used when navigating through the system.

Notes / Tips.

ENTER moves between Levels

LEFT/RIGHT moves between items within the level

When you enter a new setting the system will jump back one level in the menu system.

- The “back” selection in the menu structure will take you back one level when selected.
- When an item is selected which has several setting possibilities the first value displayed will be the value currently stored in the system. The order of the available settings for any menu item in the table supplied does not represent the order the settings will actually be displayed.
- If left unattended, the menu will default to the root display after a preset timeout.

Factory Preset Condition

The P DX 3010 is delivered preset for the following mode of operation:

- Audio Group 1 selected
- Audio Full Scale Level = 15 dBu
- CVBS, YC video output

If this is the mode of operation required, then no adjustments are necessary.

ROOT	LEVEL 1	LEVEL 2	LEVEL 3	LEVEL 4	COMMENTS
3010	AUD	GRP	NONE 1 2 3 4 back		"Normal" Root display on module = Module type
		CH12	FSLV	CH12 CH1 CH2 back	Select embedded Audio Group for deembedding
		CH34	FSLV	CH34 CH3 CH4 back	Setting Full Scale Level (FSLV) FSLV Range: -39 ... +24 dB CH12: Gang Mode, both channels
			DEMP	OFF ON back	Activation Deemphasis
		SWAP	OFF ON back		SWAP Audio Channels: Ch12 <-> Ch34
		back			

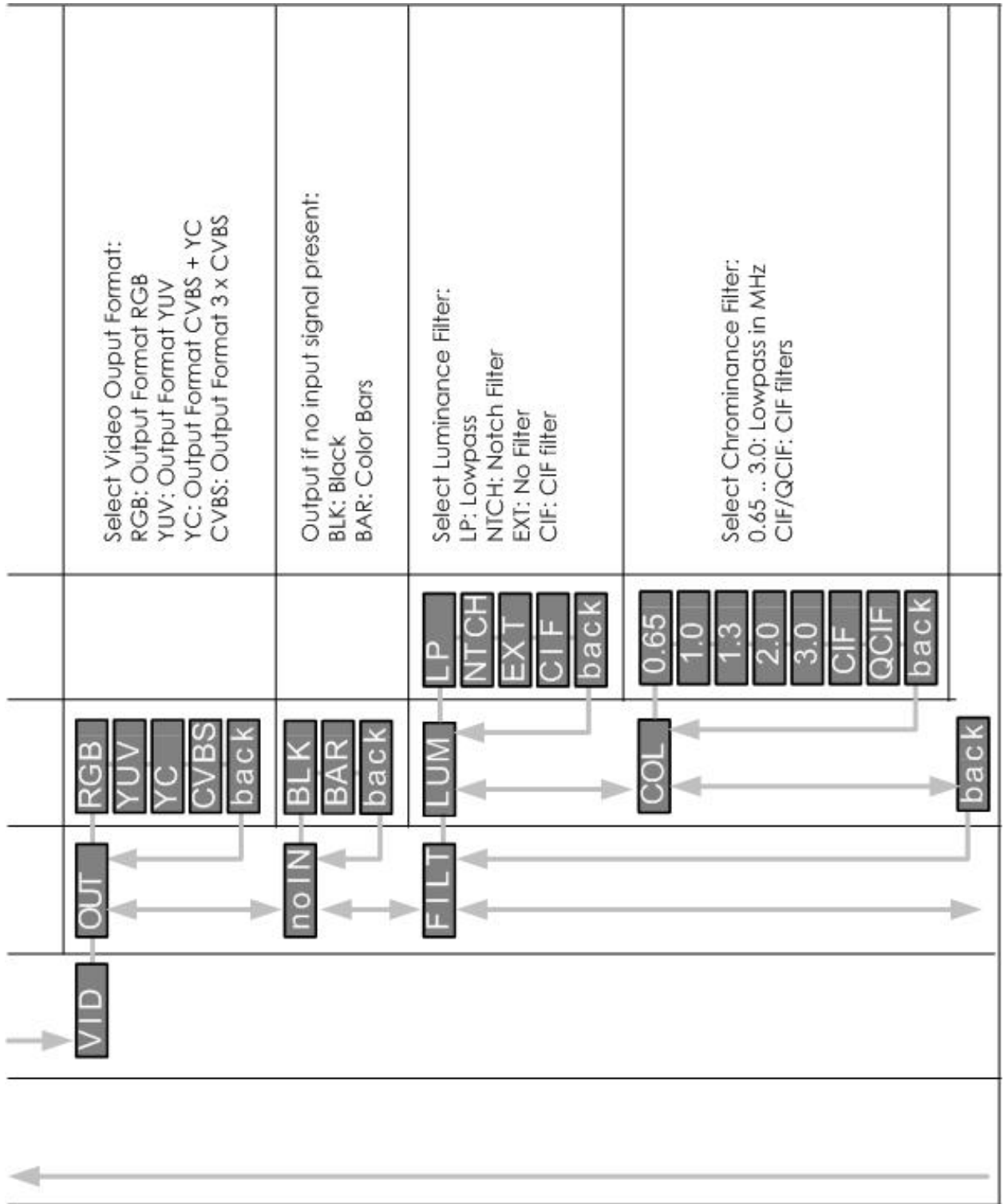

	<p>VBI</p> <p>TRA</p> <p>BLNK</p> <p>back</p>	<p>Vertical Blanking Interval (VBI) TRA: transparent BLNK: blanked</p>
<p>PED</p> <p>OFF</p> <p>ON</p> <p>back</p>	<p>Pedestal ON/OFF</p>	
<p>YSC</p> <p>000</p>	<p>Adjust Y level: 0.00 .. 1.50</p>	
<p>UVsc</p> <p>000</p>	<p>Adjust UV level: 0.00 .. 2.00</p>	
<p>BRI</p> <p>000</p>	<p>Black Setup: Adjust level: -7.5 .. 15.0</p>	
<p>LLIM</p> <p>OFF</p> <p>1.5</p> <p>6</p> <p>11</p> <p>back</p>	<p>Luminance undershoot limiter: 1.5, 6, 11 IRE</p>	

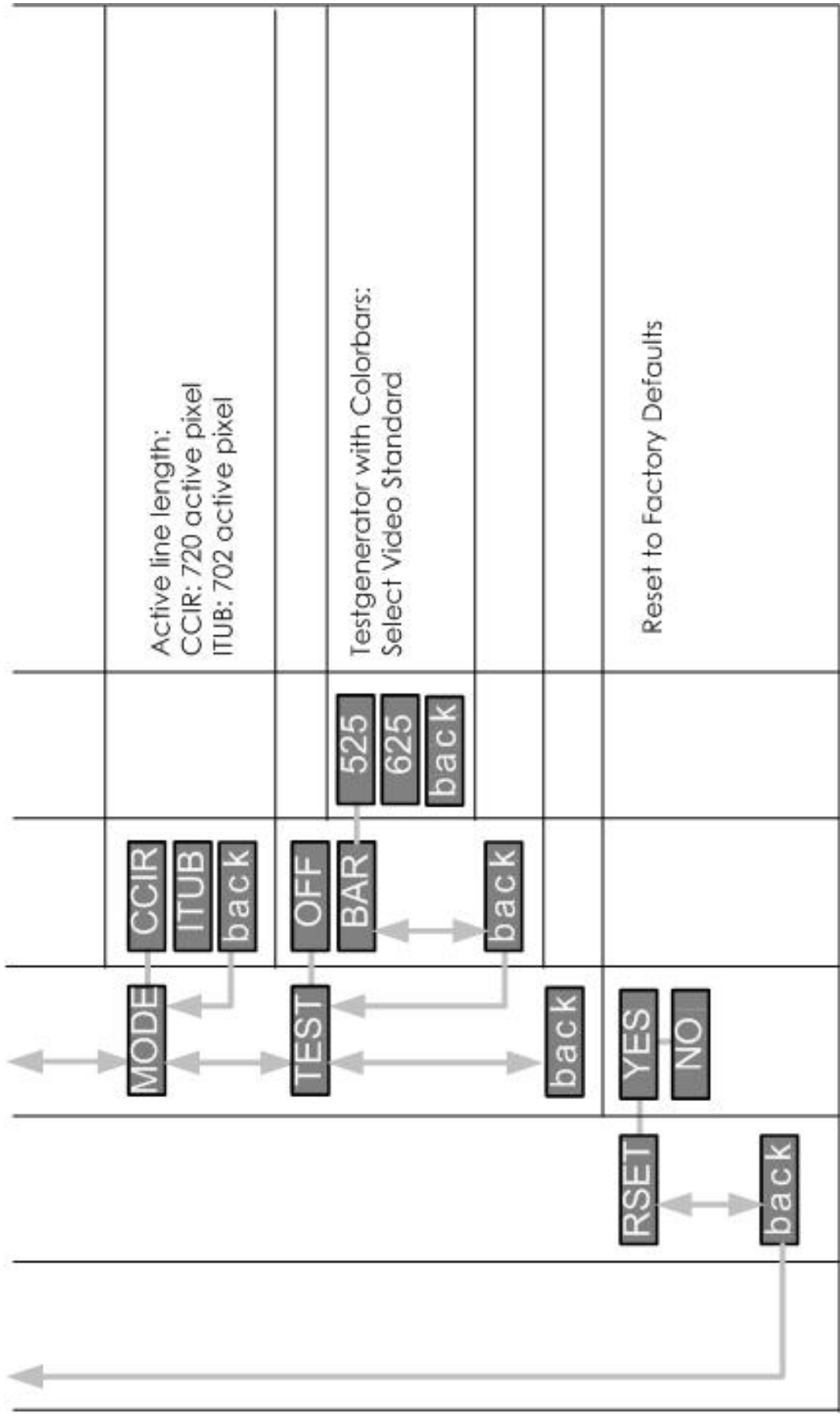

Active line length:
 CCIR: 720 active pixel
 ITUB: 702 active pixel

Testgenerator with Colorbars:
 Select Video Standard

Reset to Factory Defaults

Front Panel Alarm Indicator

There is also a single alarm LED on the front side of the module, which is designed for quick and easy indication of a problem condition in installations where visible access to the bottom of the module is not convenient.

LED Color	Indication
Green	Signal (Audio/Video) present, PLL locked, signal locked
Yellow	No Audio present or test signal selected
Red	no signal, PLL unlocked

LED **OFF** indicates power is lost, or there is a power supply fault.

Specifications (P DX 3010)

Digital Video

SDI Video in	1 x Serial Digital Video. SMPTE 259M-C
Input impedance	75 Ohm (BNC connectors)
SDI Video out	1 reclocked Serial Digital Video. SMPTE 259M-C
Output impedance	75 Ohm (BNC connectors)
Output level	0.8V p-p
Cable Equalization	Up to 250m (Belden 8281 / 270Mbit/s)
Jitter	< 0.2 UI
Return loss	> 15dB (270 MHz)

Outputs

Analog Video

Return Loss	>35dB (5,75MHz)
Signal to noise	>60dB
Quantization	10 Bits (internal processing 10Bit)
Sampling	54 MHz (4x Oversampling)
Signals	RGB or YUV or 3 x CVBS or CVBS/YC (switchable)

Outputs

Analog Audio

Signal	2 x balanced stereo outputs (one stereo output per channel)
Impedance	50 Ohm (SubD25 female connector)
Max Level	24 dBu into 10K Ohms
Full Scale Level	Adjustable between -39dB to 24dB (in 0.5dB incr.)
Quantisation	24 bits
Noise Floor	< -85 dBu (A-weighted)
Distortion	< 0.005% (20 Hz to 20 KHz)
Frequency Response	+/- 0.2dB (20 Hz to 20 KHz)
Crosstalk	< -80dB (20 Hz to 20 KHz)

Electrical Specifications

Operating Voltage	+ 5V DC
Power Consumption	7 W
Connection	DC input via 5 pin locking bayonet connector
Safety	IEC 60950/ EN 60950/VDE 0805

Mechanical

Size	85.5mm x 35.3mm x 58mm + connectors
Weight	350g

Ambient

Temperature	5°C to 35°C Maintaining specifications -20°C to +70°C Storage
Humidity	Max. 80% non condensing

Supplied Accessories

Documentation	P DX 3010 D Reference Manual
---------------	------------------------------

Available Options

Below is a list of available options for the P DX 3010 MiniModule. Please refer to product brochures or our web site for more detailed information.

Model	Description
R PS 3001 E	External brick power supply module for Series 3000 MiniModules. European market version. 100-240 VAC input, +5V DC output.
R PS 3001 U	External brick power supply module for Series 3000 MiniModules. USA market version. 110-240 VAC input, +5V DC output.
R PS 3001 -3	External desk power supply module for Series 3000 MiniModules. 110-240 VAC input, +5V DC output.
R FR 3004	4 Module mounting frame. This is a small mechanical mounting bracket for 4 MiniModules. Can be mounted with screws on any surface.
R FR 3005	Rack Frame 1. This is a basic 19-inch rack mountable frame which can accommodate 10 MiniModules with power bricks R PS 1 or can be extended with the R FR 3010.
R FR 3010	Rack Frame 2. This is a card cage with integrated central power supply, optional redundant power supply and optional controller, which can accommodate 10 MiniModules. Can be combined with R FR 3005
R PS C15	1.5m cable extension to connect one MiniModule to R FR 3010
R PS C25	2.5m cable extension to connect one MiniModule to R FR 3010
R PS 5010	Redundant power supply for the R FR 3010 card cage
R CT 5020	Rack controller for the R FR 3010 rack frame
R CT 5010	Rack Bus Extension for R FR 3010 rack frame. In combination with R CT 5020
R CT 3000	Service Adapter for remote configuration of one MiniModule via PC

Parts List

Due to the very dense design and high level of integration there are no user serviceable electronic assemblies within the P DX 3010 module.

P DX 3010 D Mini Module (complete)

Description	Monitoring Demultiplexer
Model Number	P DX 3010
Part Number	6.155.002.245

Service

If you are experiencing problems, or have questions concerning your P DX 3010 MiniModule please contact your local distributor for assistance.

We offer a fixed cost service exchange program for defective Series 3000 MiniModules out of Warranty. Please contact your distributor or check our web site for details on this program.

More detailed information and product updates may be available on our web site:

www.lynx-technik.com

You will also find links to contact us directly for assistance.

Contact Information

Please contact your local distributor; this is your local and fastest method for obtaining support and sales information.

LYNX Technik can be contacted directly using the information below.

Address LYNX Technik AG
Brunnenweg 3
64331 Weiterstadt
Germany.

Website www.lynx-technik.com

E-Mail info@lynx-technik.com

LYNX Technik manufactures a complete range of high quality modular products for broadcast and Professional markets, please contact your local representative or visit our web site for more product information.



This Page is intentionally left blank

